

WSPORNIK GÓRNY PROWADNIC

W100
W150

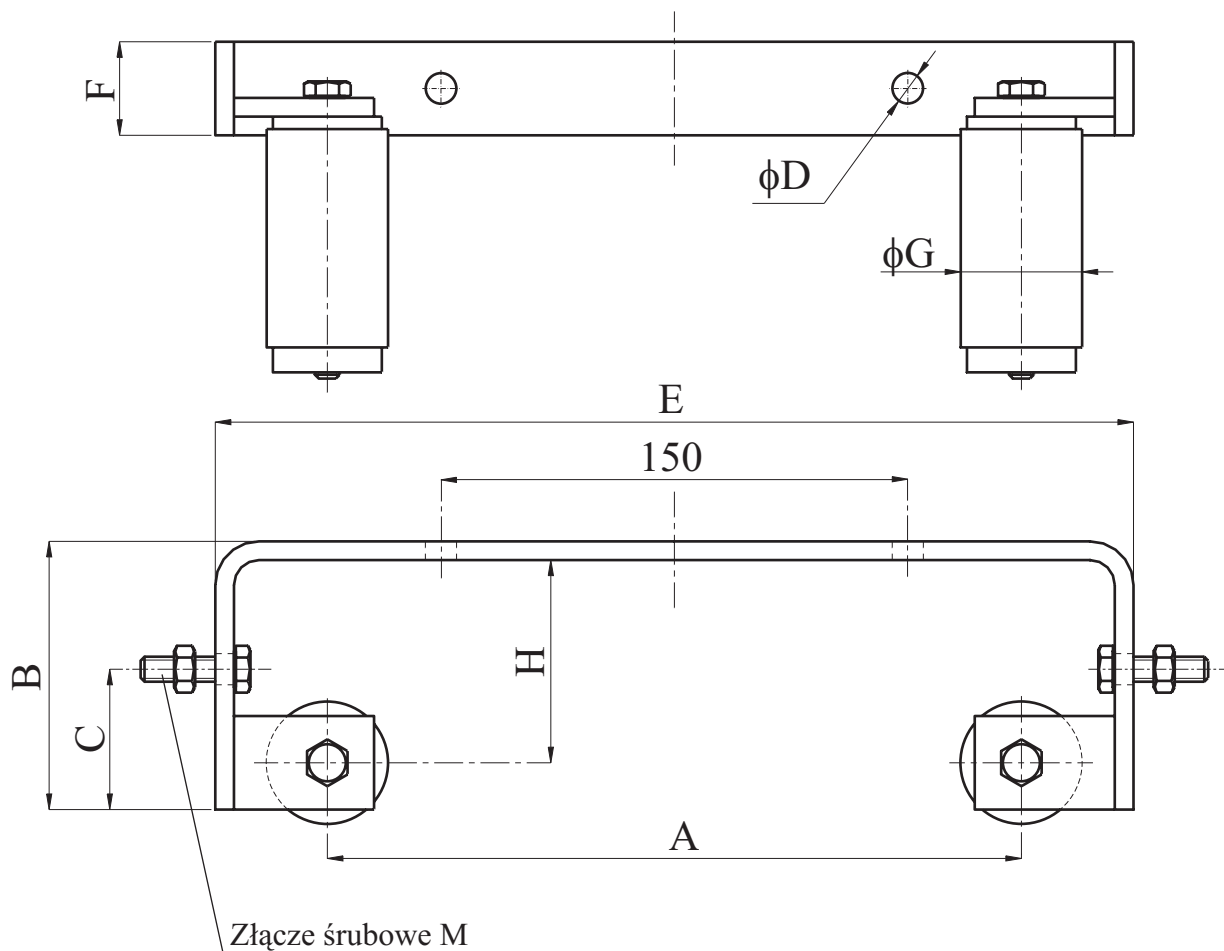

Symbol	Numer Katalogowy	Wymiary [mm]									Dla kolana sprzęgającego
		A	B	C	∅ D	E	F	∅ G	H	M	
W100		220	86	45	4x10	295	30	39	65	M8x30	KS65 ,KS80 , KS80H KS100
W150		320	90	55	4x14	395	40	50	69	M12x30	KS150

ZASTOSOWANE MATERIAŁY:

konstrukcje stalowe ocynkowane, stal nierdzewna, guma kwasoodporna

