

KOLANO SPRZĘGAJĄCE

**KS65
KS80
KS80H
KS100
KS150**

65 , 80 , 80H , 100

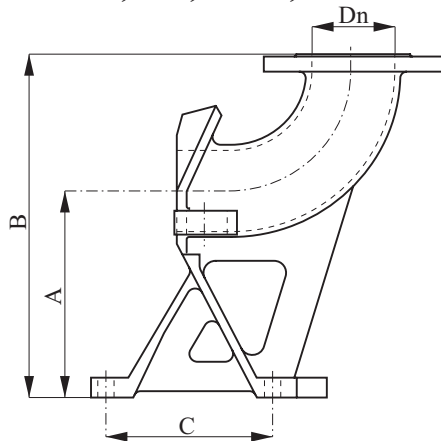

150

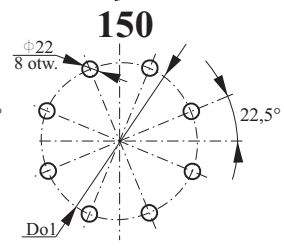
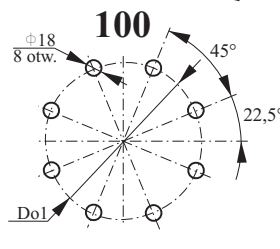
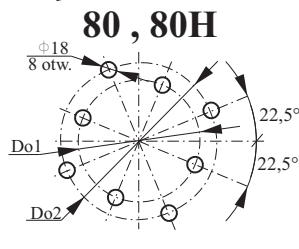
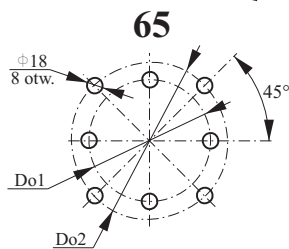
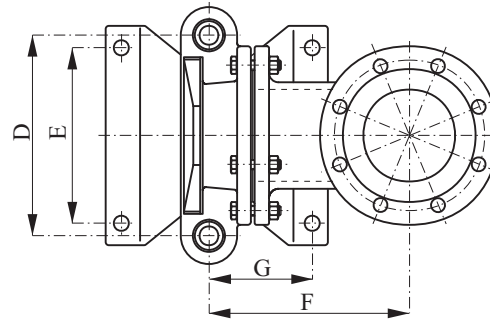
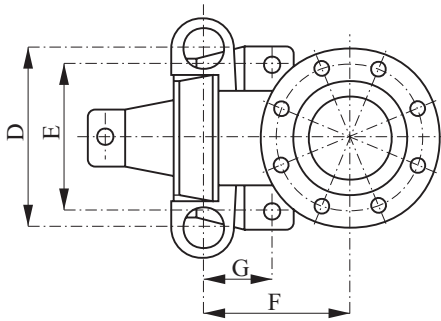
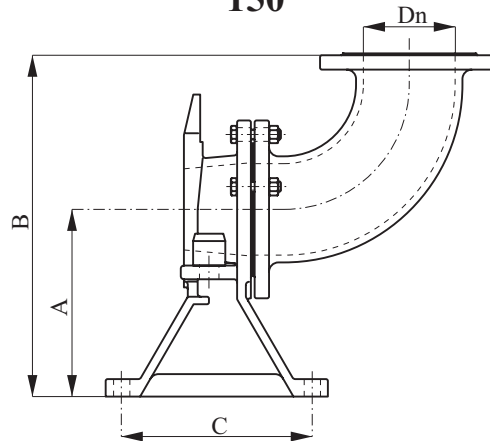

Symbol	Numer Katalogowy	Wymiary [mm]										Masa [kg]	Kołnierz dla Dn	Dla pomp w zakresie mocy [kW]
		A	B	C	D	Do1	Do2	E	F	G	Dn			
KS65		160	327	123	206	145	160	184	167	58	65	18	65,80	1,1 ÷ 3,0
KS80		160	327	123	206	160	180	184	167	58	80	18,5	80,100	1,1 ÷ 4,0
KS80H		210	377	205	206	160	180	180	167	84	80	22	80,100	MS2 (5,5 ÷ 11,5)
KS100		260	432	205	220	180	--	180	180	84	100	24,5	100	3,0 ÷ 11,5
KS150		300	550	305	320	240	--	280	320	165	150	77	150	12,5 ÷ 22,0

ZASTOSOWANE MATERIAŁY:

żeliwo ZL250, stal nierdzewna, guma kwasoodporna