

ZAWÓR ZWROTNY KĄTOWY KWASOODPORNY V-YYEB40

CHARAKTERYSTYKA:

Średnica	-	15 -250 mm;
Ciśnienie	-	40 bar (możliwe jest wykonanie z kołnierzami na 6, 10, 16, 25 bar);
Temperatura	-	do 250°C dla kwasów i ługów;
	-	do 550°C dla substancji neutralnych (dla uszczelnienia miękkiego ≤ 200°C);
Medium	-	kwasy i ługi, woda, para wodna i inne neutralne ciekłe i gazowe substancje, a także paliwa ropopochodne.

WYKONANIE: typ materiału kadłuba / przyłącza / rodzaj grzyba i pierścienia grzyba / inne

Przykład: V-YYEB40 / --- / --- / ---

Przykład: V-YYEA40 / S / P / ---

Typ materiału kadłuba	Znak	Przyłącza	Znak	Rodzaj grzyba i pierścienia grzyba	Znak	Inne	Znak
X6CrNi18-10 lub GX5CrNi19-10	V-YYEB40	Kołnierze	---	Standardowy	---	-----	---
		Do spawania	S	Pierścień z PTFE	P		
		Do spawania	SW	Pierścień z NBR	N		
X2CrNiMo17-12-2 lub GX5CrNiMo19-11-2	V-YYEA40	Z wewnętrznym gwintem	G				

ZASTOSOWANIE:

Zawory zwrotne przeznaczone są do ochrony rurociągów przed strumieniem powrotnym czynnika roboczego.

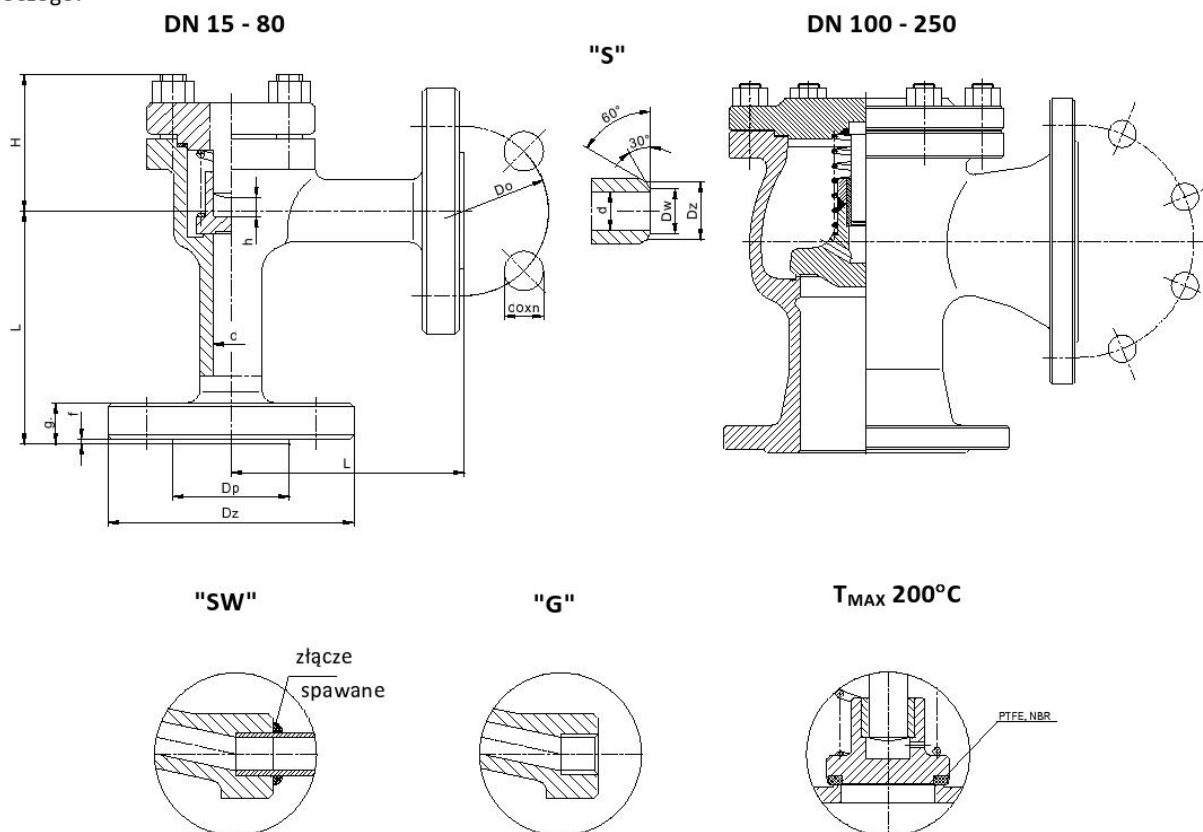

MATERIAŁY:

Wykonanie	V-YYEB40	V-YYEA40	V-YYEB40	V-YYEA40
Część	DN 15 - 80			
Kadłub, pokrywa	X6CrNiTi18-10 (1.4541)	X2CrNiMo17-12-2 (1.4404)	GX5CrNi19-10 (1.4308)	GX5CrNiMo19-11-2 (1.4408)
Grzyb	X6CrNiTi18-10 (1.4541)	X2CrNiMo17-12-2 (1.4404)	X6CrNiTi18-10 (1.4541)	X2CrNiMo17-12-2 (1.4404)
Sprężyna	X6CrNiTi18-10 (1.4541)			
Uszczelnienie pokrywy	Grafit			

WYMIARY:

DN	Standardowe - kołnierze																Do spawania "S"		
	PN 40											PN 16					Dz	Dw	Masa
	Dz	Dp	Do	do	n	L	g.	f	H	h	Masa	Dz	Dp	Do	do	n			
15	95	45	65	14	4	90	16	2	65	9	2,50	95	45	65	14	4	22	17	0,80
20	105	58	75	14	4	95	18	2	65	9	3,50	105	58	75	14	4	28	22	1,20
25	115	68	85	14	4	100	18	2	65	9	3,90	115	68	85	14	4	35	28,5	1,25
32	140	78	100	18	4	105	18	2	75	13	6,80	140	78	100	18	4	44	37	2,90
40	150	88	110	18	4	115	18	3	90	15	8,90	150	88	110	18	4	50	43	4,40
50	165	102	125	18	4	125	20	3	105	18	10,00	165	102	125	18	4	62	54	4,20
65	185	122	145	18	8	145	22	3	130	22	13,50	185	122	145	18	4	77	69	5,80
80	200	138	160	18	8	155	24	3	155	26	21,00	200	138	160	18	8	91	81	11,50
100	235	162	190	22	8	175	24	3	165	32	41,20	220	158	180	18	8	117	104	28,80
125	270	188	220	26	8	200	26	3	175	40	51,60	250	184	210	18	8	144	130,5	34,60
150	300	218	250	26	8	225	28	3	186	46	62,00	285	212	240	22	8	172	156,5	40,90
200	375	285	320	30	12	275	34	3	205	58	125,00	340	268	295	22	12	223	204,5	86,70
250	450	306	385	33	12	325	38	3	290	70	165,00	405	320	355	26	12	278	256,5	109,50

DANE TECHNICZNE:

Materiał kadłuba	Czynnik roboczy	PN	Najwyższe ciśnienie robocze przy temperaturze czynnika																
			20°C	100°C	150°C	200°C	250°C	300°C	350°C	400°C	450°C	480°C	500°C	510°C	520°C	530°C	540°C	550°C	
X6CrNiTi18-10 (1.4541)	kwasy i ługi	40	40,0	39,6	37,3	35,4	33,7	-	-	-	-	-	-	-	-	-	-	-	-
GX5CrNi19-10 (1.4308)		40	40,0	36,3	32,7	29,9	27,6	-	-	-	-	-	-	-	-	-	-	-	-
X6CrNiTi18-10 (1.4541)	substancje neutralne	40	40,0	39,6	37,3	35,4	33,7	31,8	30,6	29,7	29,0	28,7	28,3	28,0	27,8	27,5	27,2	27,0	
GX5CrNi19-10 (1.4308)		40	40,0	36,3	32,7	29,9	27,6	25,7	24,5	23,8	23,3	23,0	22,8	22,0	19,5	18,9	18,0	17,5	