

ZAWÓR ZWROTNY KĄTOWY V-104

CHARAKTERYSTYKA:

Średnica	-	15 -250 mm;
Ciśnienie	-	40 bar (możliwe jest wykonanie z kołnierzami na 6, 10, 16, 25 bar);
Temperatura	-	do 530°C (dla uszczelnienia miękkiego ≤ 200°C);
Medium	-	woda, para wodna i inne neutralne ciekłe i gazowe substancje, a także paliwa ropopochodne i woda morską.

WYKONANIE: typ / przyłącza / materiał kadłuba / rodzaj grzyba i pierścienia grzyba / inne

Przykład: V-104 / --- / --- / --- / ---

Przykład: V-104 / S / U / P / ---

Przyłącza	Znak	Materiał kadłuba	Znak	Rodzaj grzyba i pierścienia grzyba	Znak	Inne	Znak
Kołnierze	---	(P250GH) C 22.8 lub GP240GH	---	Standardowy	---	Warunki morskie	WM
Do spawania	S			Pierścień z PTFE	P		
Do spawania	SW	16Mo3 lub G20Mo5	U	Pierścień z NBR	N		
Z wewnętrznym gwintem	G			Pierścień STELLIT	L		

ZASTOSOWANIE:

Zawory zwrotne przeznaczone są do ochrony rurociągów przed strumieniem powrotnym czynnika roboczego.

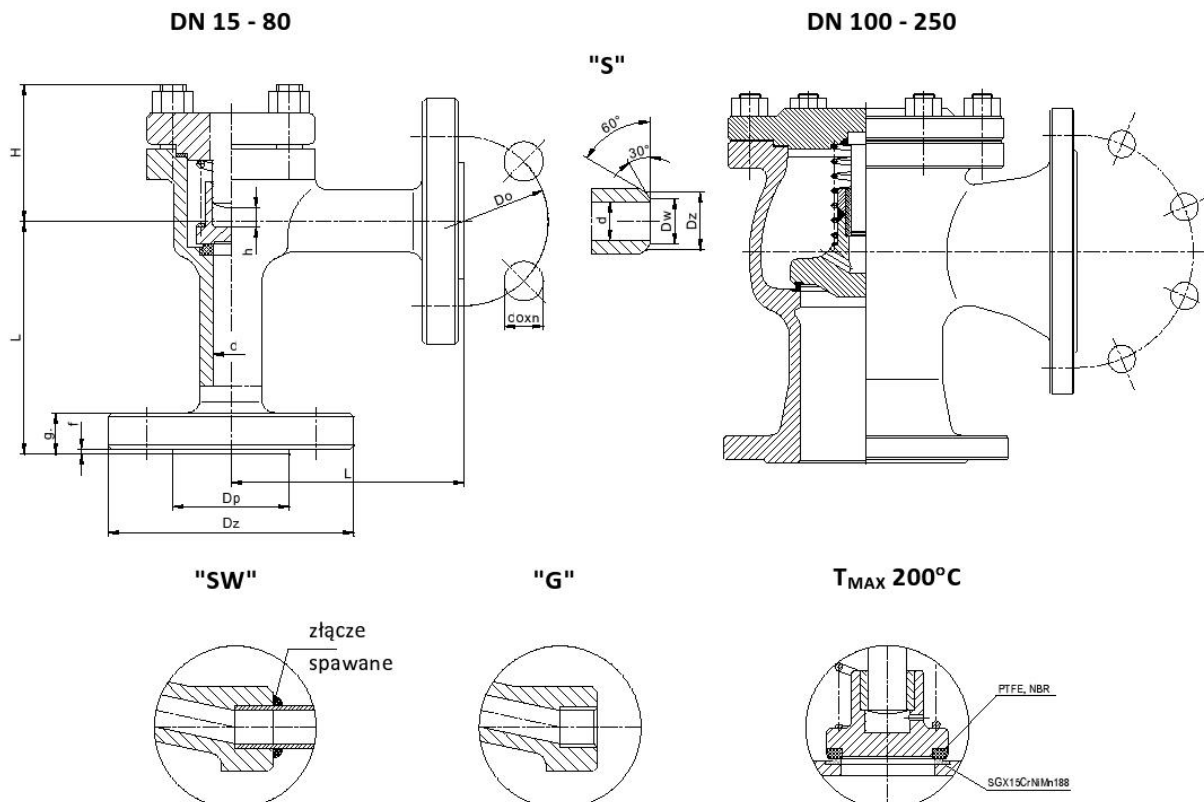

MATERIAŁY:

Wykonanie	Standardowe	U	Standardowe	U				
Część	T _{MAX} 450°C		T _{MAX} 530°C					
	DN 15 - 80				DN 100 - 250			
Kadłub, pokrywa	(P250GH) C22.8 (1.0460)		16Mo3 (1.5415)		GP240GH (1.0619)		G20Mo5 (1.5419)	
Pireścić siedliska	G 18 8 Mn (1.4370) lub Stellite , lub CW306G							
Grzyb	X30Cr13 (1.4028) , X17CrNi16-2 (1.4057) , P250GH (1.0460) , CW306G							
Pierścień grzyba	G 18 8 Mn (1.4370) lub Stellite , CW306G , PTFE , NBR							
Sprężyna	51CrV4 (1.2241)							
Uszczelnienie pokrywy	Grafit							

WYMIARY:

DN	Standardowe - kołnierze											Do spawania "S"							
	PN 40											PN 16					Dz	Dw	Masa
	Dz	Dp	Do	do	n	L	g.	f	H	h	Masa	Dz	Dp	Do	do	n			
15	95	45	65	14	4	90	16	2	65	9	2,50	95	45	65	14	4	22	17	0,80
20	105	58	75	14	4	95	18	2	65	9	3,50	105	58	75	14	4	28	22	1,20
25	115	68	85	14	4	100	18	2	65	9	3,90	115	68	85	14	4	35	28,5	1,25
32	140	78	100	18	4	105	18	2	75	13	6,80	140	78	100	18	4	44	37	2,90
40	150	88	110	18	4	115	18	3	90	15	8,90	150	88	110	18	4	50	43	4,40
50	165	102	125	18	4	125	20	3	105	18	10,00	165	102	125	18	4	62	54	4,20
65	185	122	145	18	8	145	22	3	130	22	13,50	185	122	145	18	4	77	69	5,80
80	200	138	160	18	8	155	24	3	155	26	21,00	200	138	160	18	8	91	81	11,50
100	235	162	190	22	8	175	24	3	165	32	41,20	220	158	180	18	8	117	104	28,80
125	270	188	220	26	8	200	26	3	175	40	51,60	250	184	210	18	8	144	130,5	34,60
150	300	218	250	26	8	225	28	3	186	46	62,00	285	212	240	22	8	172	156,5	40,90
200	375	285	320	30	12	275	34	3	205	58	125,00	340	268	295	22	12	223	204,5	86,70
250	450	306	385	33	12	325	38	3	290	70	165,00	405	320	355	26	12	278	256,5	109,50

DANE TECHNICZNE:

Materiał kadłuba	PN	Najwyższe ciśnienie robocze przy temperaturze czynnika																
		20°C	100°C	150°C	200°C	250°C	300°C	350°C	400°C	450°C	480°C	500°C	510°C	520°C	530°C	540°C	550°C	560°C
		bar																
(P250GH)C 22.8 (1.0460)	40	40,0	37,1	35,2	33,3	30,5	27,6	25,7	23,8	13,1	-	-	-	-	-	-	-	-
16Mo3 (1.5415)	40	40,0	40,0	40,0	40,0	39,0	34,3	32,4	30,5	29,5	22,4	17,7	14,5	11,2	9,0	-	-	-
GP240GH (1.0619)	40	40,0	37,1	35,2	33,3	30,5	27,6	25,7	23,8	13,1	-	-	-	-	-	-	-	-
G20Mo5 (1.5419)	40	40,0	40,0	40,0	40,0	39,0	34,3	32,4	30,5	29,5	22,4	17,7	14,5	11,2	9,0	-	-	-