

ZAWÓR ZWROTNY KWASOODPORNY V-YYB40

CHARAKTERYSTYKA:

Średnica	-	15 -300 mm;
Ciśnienie	-	40 bar (możliwe jest wykonanie z kołnierzami na 6, 10, 16, 25 bar);
Temperatura	-	do 250°C dla kwasów i ługów;
	-	do 550°C dla substancji neutralnych (dla uszczelnienia miękkiego ≤ 200°C);
Medium	-	kwasy i ługi, woda, para wodna i inne neutralne ciekłe i gazowe substancje, a także paliwa ropopochodne.

WYKONANIE: typ materiał kadłuba / przyłącza / rodzaj grzyba i pierścienia grzyba / inne

Przykład: V-YYB40 / --- / --- / ---

Przykład: V-YYA40 / S / P / ---

Typ materiał kadłuba	Znak	Przyłącza	Znak	Rodzaj grzyba i pierścienia grzyba	Znak	Inne	Znak
X6CrNi18-10 lub GX5CrNi19-10	V-YYB40	Kołnierze	---	Standardowy	---	-----	---
		Do spawania	S	Pierścień z PTFE	P		
		Do spawania	SW	Pierścień z NBR	N		
X2CrNiMo17-12-2 lub GX5CrNiMo19-11-2	V-YYA40	Z wewnętrznym gwintem	G				

ZASTOSOWANIE:

Zawory zwrotne przeznaczone są do ochrony rurociągu przed strumieniem powrotnym czynnika roboczego.

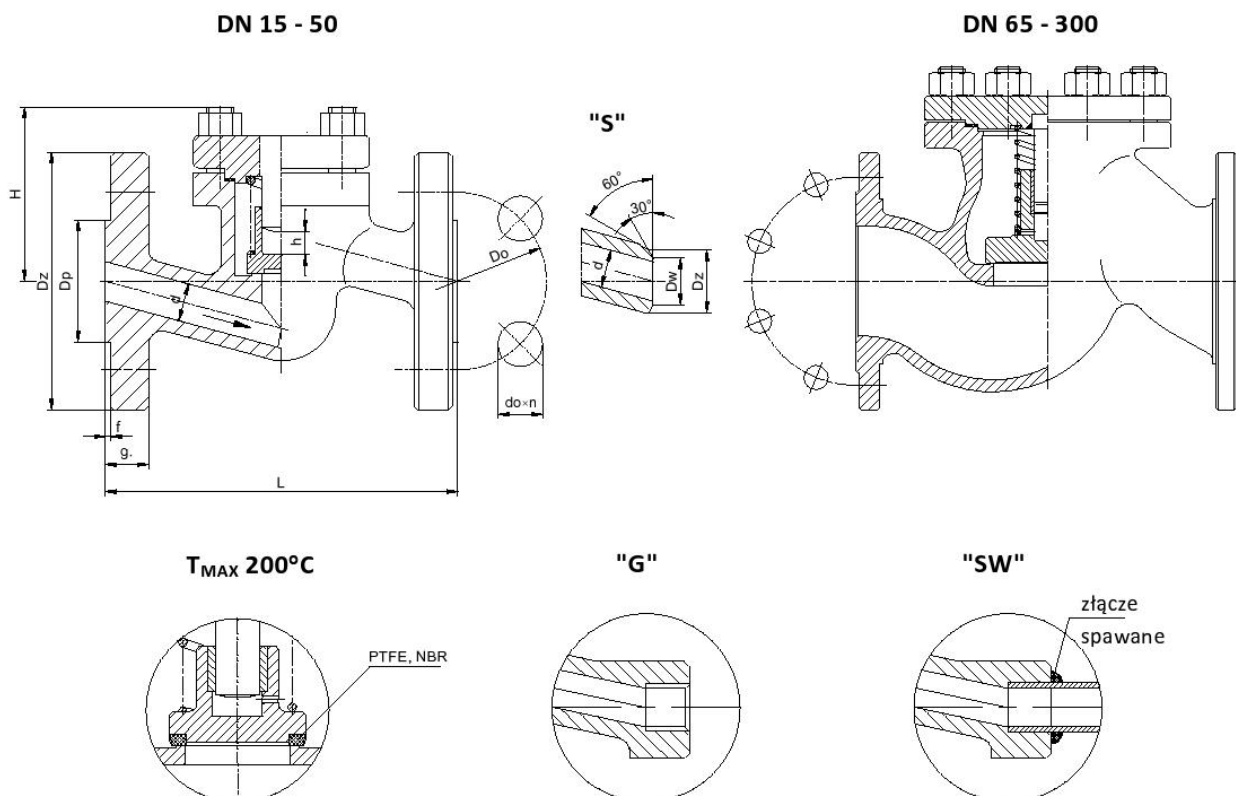

MATERIAŁY:

Wykonanie	V-YYB40	V-YYA40	V-YYB40	V-YYA40
Część	DN 15 - 50			
Kadłub, pokrywa	X6CrNiTi18-10 (1.4541)	X2CrNiMo17-12-2 (1.4404)	GX5CrNi19-10 (1.4308)	GX5CrNiMo19-11-2 (1.4408)
Grzyb	X6CrNiTi18-10 (1.4541)	X2CrNiMo17-12-2 (1.4404)	X6CrNiTi18-10 (1.4541)	X2CrNiMo17-12-2 (1.4404)
Sprężyna	X6CrNiTi18-10 (1.4541)			
Uszczelnienie pokrywy	Grafit			

WYMIARY:

DN	Standardowe - kołnierze												Do spawania „S”						
	PN 40											PN 16					Dz	Dw	Masa
	Dz	Dp	Do	do	n	L	g.	f	H	h	Masa	Dz	Dp	Do	do	n			
15	95	45	65	14	4	130	16	2	65	10	2,50	95	45	65	14	4	22	17	1,10
20	105	58	75	14	4	150	18	2	65	10	2,90	105	58	75	14	4	28	22	1,40
25	115	68	85	14	4	160	18	2	65	10	3,30	115	68	85	14	4	35	28,5	1,70
32	140	78	100	18	4	180	18	2	85	15	6,80	140	78	100	18	4	44	37	3,60
40	150	88	110	18	4	200	18	3	95	17	9,00	150	88	110	18	4	50	43	4,70
50	165	102	125	18	4	230	20	3	110	21	10,50	165	102	125	18	4	62	54	6,10
65	185	122	145	18	8	290	22	3	155	22	17,50	185	122	145	18	4	77	69	12,70
80	200	138	160	18	8	310	24	3	170	26	27,00	200	138	160	18	8	91	81	18,50
100	235	162	190	22	8	350	24	3	195	32	41,00	220	158	180	18	8	117	104	36,00
125	270	188	220	26	8	400	26	3	200	40	54,00	250	184	210	18	8	144	130,5	49,00
150	300	218	250	26	8	480	28	3	225	44	90,00	285	212	240	22	8	172	156,5	76,00
200	375	285	320	30	12	600	34	3	270	60	150,00	340	268	295	22	12	223	204,5	140,00
250	450	306	385	33	12	730	38	3	290	70	195,00	405	320	355	26	12	278	256,5	165,00
300	515	410	450	33	16	850	42	3	410	130	360,00	460	370	410	26	12	329	306,5	280,00

DANE TECHNICZNE:

Materiał kadłuba	Czynnik roboczy	PN	Najwyższe ciśnienie robocze przy temperaturze czynnika																	
			20°C	100°C	150°C	200°C	250°C	300°C	350°C	400°C	450°C	480°C	500°C	510°C	520°C	530°C	540°C	550°C		
			bar																	
X6CrNiTi18-10 (1.4541)	kwasy i tugi	40	40,0	39,6	37,3	35,4	33,7	-	-	-	-	-	-	-	-	-	-	-	-	
GX5CrNi19-10 (1.4308)		40	40,0	36,3	32,7	29,9	27,6	-	-	-	-	-	-	-	-	-	-	-	-	-
X6CrNiTi18-10 (1.4541)	substancje neutralne	40	40,0	39,6	37,3	35,4	33,7	31,8	30,6	29,7	29,0	28,7	28,3	28,0	27,8	27,5	27,2	27,0		
GX5CrNi19-10 (1.4308)		40	40,0	36,3	32,7	29,9	27,6	25,7	24,5	23,8	23,3	23,0	22,8	22,0	19,5	18,9	18,0	17,5		