

ZAWÓR ZWROTNY KWASOODPORNY V-YYB100

CHARAKTERYSTYKA:

Średnica	-	15 -200 mm;
Ciśnienie	-	100 bar ;
Temperatura	-	do 250°C dla kwasów i ługów;
	-	do 550°C dla substancji neutralnych (dla uszczelnienia miękkiego ≤ 200°C);
Medium	-	kwasy i ługi, woda, para wodna i inne neutralne ciekłe i gazowe substancje a także paliwa ropopochodne.

WYKONANIE: typ materiału kadłuba / przyłącza / rodzaj grzyba i pierścienia grzyba / inne

Przykład: V-YYB100 / --- / --- / ---

Przykład: V-YYB100 / S / P / ---

Typ materiału kadłuba	Znak	Przyłącza	Znak	Rodzaj grzyba i pierścienia grzyba	Znak	Inne	Znak
X6CrNi18-10 lub GX5CrNi19-10	V-YYB100	Kołnierze	---	Standardowy	---	-----	---
		Do spawania	S	Pierścień z PTFE	P		
X2CrNiMo17-12-2 lub GX5CrNiMo19-11-2	V-YYA100	Do spawania	SW	Pierścień z NBR	N		
		Z wewnętrznym gwintem	G				

ZASTOSOWANIE:

Zawory zwrotne przeznaczone są do ochrony rurociągu przed strumieniem powrotnym czynnika roboczego.

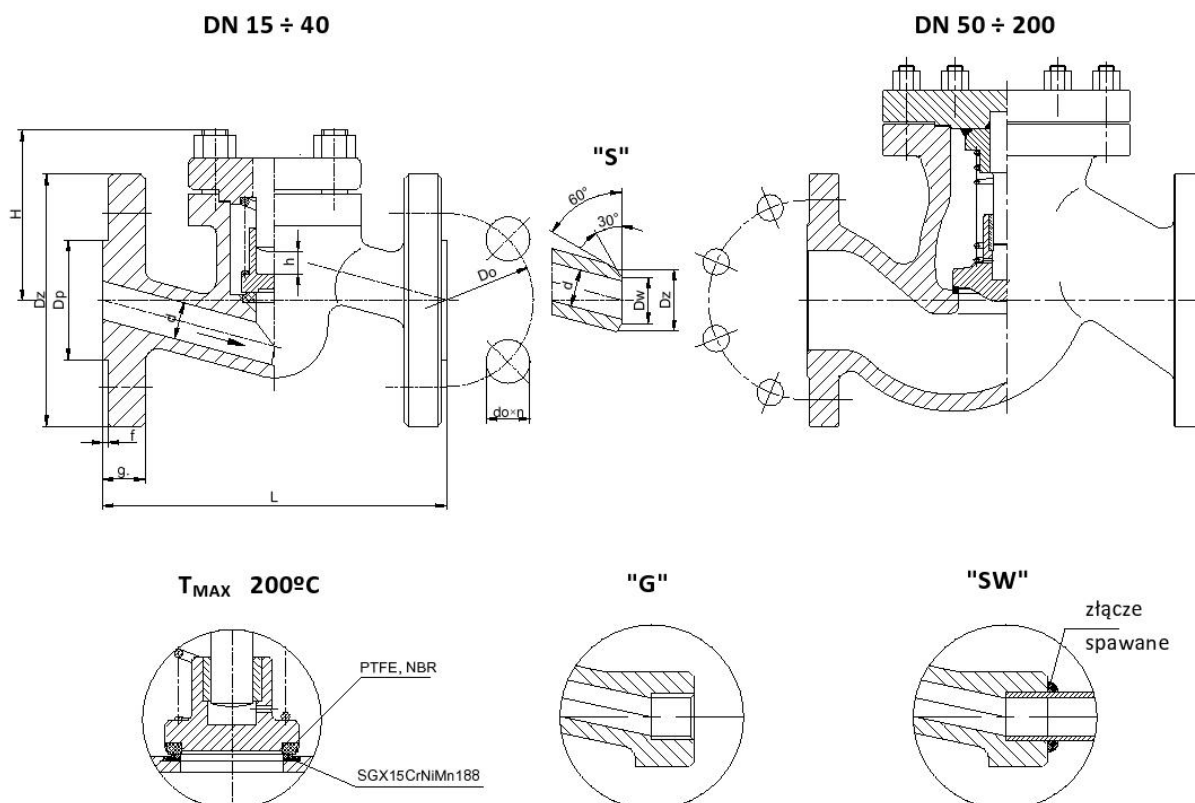

MATERIAŁY:

Wykonanie	V-YYB100	V-YYA100	V-YYB100	V-YYA100
Część	DN 15 - 50			
Kadłub, pokrywa	X6CrNiTi18-10 (1.4541)	X2CrNiMo17-12-2 (1.4404)	GX5CrNi19-10 (1.4308)	GX5CrNiMo19-11-2 (1.4408)
Grzyb	X6CrNiTi18-10 (1.4541)	X2CrNiMo17-12-2 (1.4404)	X6CrNiTi18-10 (1.4541)	X2CrNiMo17-12-2 (1.4404)
Sprężyna	X6CrNiTi18-10 (1.4541)			
Uszczelnienie pokrywy	Grafit			

WYMIARY:

Standard - kołnierz													Końcówka do spawania			
DN	d	Dz	Dp	Do	do	n	L	g.	f	H	h	Masa	Dz	Dw	L	Masa
15	14	105	45	75	14	4	210	20	2	70	13	4,00	22	17	160	2,70
20	19	130	58	90	18	4	230	22	2	75	13	6,20	28	21,5	160	2,70
25	23	140	68	100	22	4	230	24	2	75	13	8,30	35	28,5	160	2,70
32	30	155	78	110	22	4	260	24	2	95	16	11,50	44	36	230	5,20
40	38	170	88	125	22	4	260	28	3	95	18	14,80	50	43	230	7,70
50	45	180	102	135	22	4	300	26	3	140	22	15,70	62	54	300	12,90
65	62	205	122	160	22	8	340	26	3	170	30	37,50	77	69	340	26,30
80	73	215	138	170	22	8	380	28	3	195	40	40,30	91	81	380	27,50
100	94	250	162	200	22	8	430	30	3	200	55	54,00	117	104	430	37,20
125	120	295	188	240	26	8	500	34	3	225	65	76,00	144	127	500	48,90
150	144	345	218	290	33	8	550	36	3	300	70	151,00	172	154	550	101,10
200	195	415	285	345	36	12	650	42	3	400	100	215,00	223	199,5	650	135,00

DANE TECHNICZNE:

Materiał kadłuba	Czynnik roboczy	PN	Najwyższe ciśnienie robocze przy temperaturze czynnika															
			20°C	100°C	150°C	200°C	250°C	300°C	350°C	400°C	450°C	480°C	500°C	510°C	520°C	530°C	540°C	550°C
X6CrNiTi18-10 (1.4541)	kwasy i ługi	100	100,0	99,0	93,3	88,5	84,2	-	-	-	-	-	-	-	-	-	-	-
GX5CrNi19-10 (1.4308)		100	100,0	90,9	81,9	74,7	69,0	-	-	-	-	-	-	-	-	-	-	-
X6CrNiTi18-10 (1.4541)	substancje neutralne	100	100,0	99,0	93,3	88,5	84,2	79,5	76,6	74,2	72,6	71,5	70,9	70,0	69,5	68,7	68,0	67,6
GX5CrNi19-10 (1.4308)		100	100,0	90,9	81,9	74,7	69,0	64,2	61,4	59,5	58,3	57,5	57,1	55,0	48,7	47,2	45,0	43,8
X2CrNiMo17-12-2 (1.4404)	kwasy i ługi	100	100,0	100,0	98,0	93,0	92,0	-	-	-	-	-	-	-	-	-	-	-
GX5CrNiMo19-11-2 (1.4408)		100	100,0	81,0	73,0	64,0	60,0	-	-	-	-	-	-	-	-	-	-	-
X2CrNiMo17-12-2 (1.4404)	substancje neutralne	100	100,0	100,0	98,0	93,0	92,0	86,0	83,0	80,0	78,0	77,0	76,0	76,0	76,0	76,0	76,0	76,0
GX5CrNiMo19-11-2 (1.4408)		100	100,0	81,0	73,0	64,0	60,0	55,0	52,0	50,0	49,0	49,0	48,0	48,0	48,0	47,0	47,0	47,0