

ZAWÓR ZWROTNY KWASOODPORNY V- YYB160

CHARAKTERYSTYKA:

Średnica	-	15 -200 mm;
Ciśnienie	-	160 bar;
Temperatura	-	do 250°C;
	-	do 550°C dla substancji neutralnych (dla uszczelnienia miękkiego ≤ 200°C);
Medium	-	kwasy i ługi, woda, para wodna i inne neutralne ciekłe i gazowe substancje, a także paliwa ropopochodne.

WYKONANIE: typ / przyłącza / materiał kadłuba / rodzaj grzyba i pierścienia grzyba / inne

Przykład: V-YYB160 / --- / --- / --- / ---

Przykład: V-YYB160 / S / U / --- / ---

Typ materiału kadłuba	Znak	Końcówki	Znak	Rodzaj grzyba i pierścień grzyba	Znak	Inne	Znak
X6CrNi18-10 lub GX5CrNi19-10	V-YYB160	Końnierze	---	Standard	---	-----	---
		Do spawania	S	Stellit	L		
X2CrNiMo17-12-2 lub GX5CrNiMo19-11-2	V-YYA160	Do spawania	SW				
		Z wewnętrznym gwintem	G				

ZASTOSOWANIE:

Zawory zwrotne przeznaczone są do ochrony rurociągu przed strumieniem powrotnym czynnika roboczego.

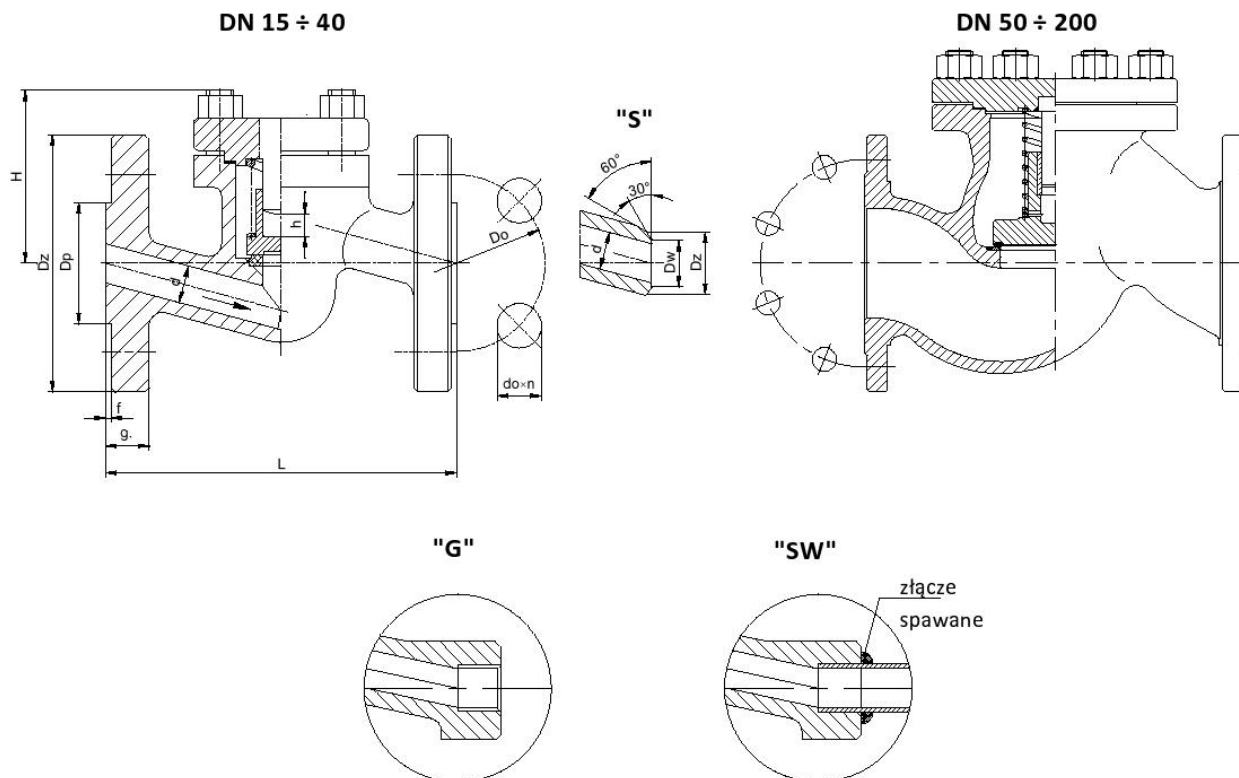

MATERIAŁY:

Wykonanie	V-YYB160	V-YYA160	V-YYB160	V-YYA160
Część	DN 15 - 50		DN 65 - 300	
Kadłub, pokrywa	X6CrNiTi18-10 (1.4541)	X2CrNiMo17-12-2 (1.4404)	GX5CrNi19-10 (1.4308)	GX5CrNiMo19-11-2 (1.4408)
Grzyb	X6CrNiTi18-10 (1.4541)	X2CrNiMo17-12-2 (1.4404)	X6CrNiTi18-10 (1.4541)	X2CrNiMo17-12-2 (1.4404)
Sprężyna	X6CrNiTi18-10 (1.4541)			
Uszczelnienie pokrywy	Grafit			

WYMIARY:

Standardowe - kołnierze													Do spawania „S”			
DN	d	Dz	Dp	Do	do	n	L	g.	f	H	h	Masa	Dz	Dw	L	Masa
15	14	105	45	75	14	4	210	20	2	70	13	4,00	22	17	160	2,70
20	19	130	58	90	18	4	230	22	2	75	13	6,20	28	21	160	2,70
25	23	140	68	100	18	4	230	24	2	75	13	8,30	35	27	160	2,70
32	30	155	78	110	22	4	260	24	2	95	16	11,50	44	34,5	230	5,20
40	38	170	88	125	22	4	260	28	3	95	18	14,80	50	43	230	7,70
50	45	195	102	145	26	4	300	30	3	140	22	15,70	62	52,5	300	12,90
65	62	220	122	170	26	8	340	34	3	170	30	37,50	77	65	340	26,30
80	73	230	138	180	26	8	380	36	3	195	40	40,30	91	76,5	380	27,50
100	94	265	162	210	30	8	430	40	3	200	55	54,00	117	98,5	430	37,20
125	120	315	188	250	33	8	500	44	3	225	95	76,00	144	120,5	500	48,90
150	144	355	218	290	33	12	550	50	3	300	100	151,00	172	144,5	550	101,10
200	195	430	285	360	36	12	650	60	3	400	110	210,00	223	189	650	145,00

DANE TECHNICZNE:

Materiał kadłuba	Medium	PN	Najwyższe ciśnienie robocze przy temperaturze czynnika															
			20°C	100°C	150°C	200°C	250°C	300°C	350°C	400°C	450°C	480°C	500°C	510°C	520°C	530°C	540°C	550°C
X6CrNiTi18-10 (1.4541)	Kwasy i ługi	160	160	159	149	142	135	-	-	-	-	-	-	-	-	-	-	-
			160	122	109	95	89	-	-	-	-	-	-	-	-	-	-	-
GX5CrNi19-10 (1.4308)	Substancje neutralne	160	160	159	149	142	135	127	123	119	116	115	113	113	113	113	112	108
			160	122	109	95	89	84	78	72	67	64	61	-	-	-	-	-
X2CrNiMo17-12-2 (1.4404)	Kwasy i ługi	160	160	160	156	149	147	-	-	-	-	-	-	-	-	-	-	-
			160	129	116	103	95	-	-	-	-	-	-	-	-	-	-	-
GX5CrNiMo19-11-2 (1.4408)	Substancje neutralne	160	160	160	156	149	147	138	132	129	125	123	122	122	121	121	121	121
			160	129	116	103	95	88	84	80	78	78	77	-	-	-	-	-